

Light Sensor Attachment

Building Instructions

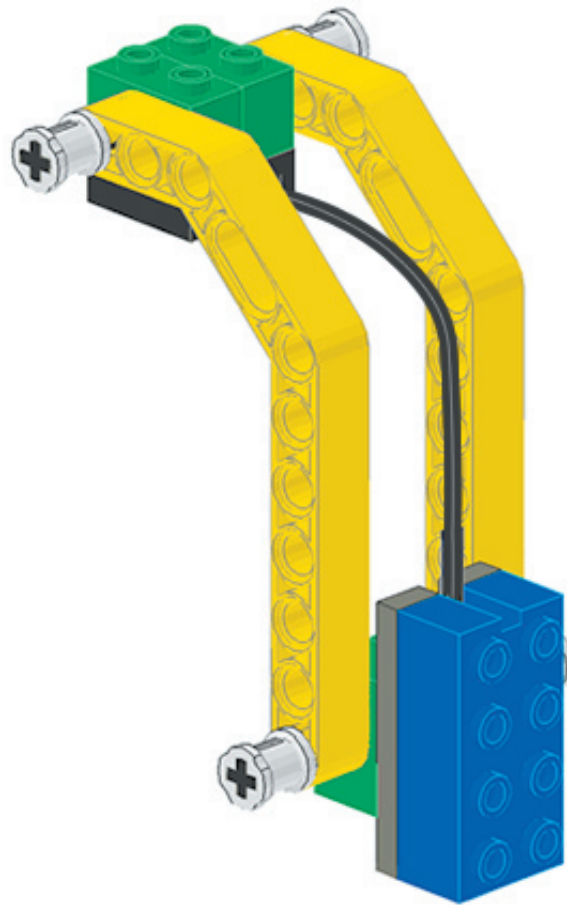

Light Sensor Attachment Parts Page

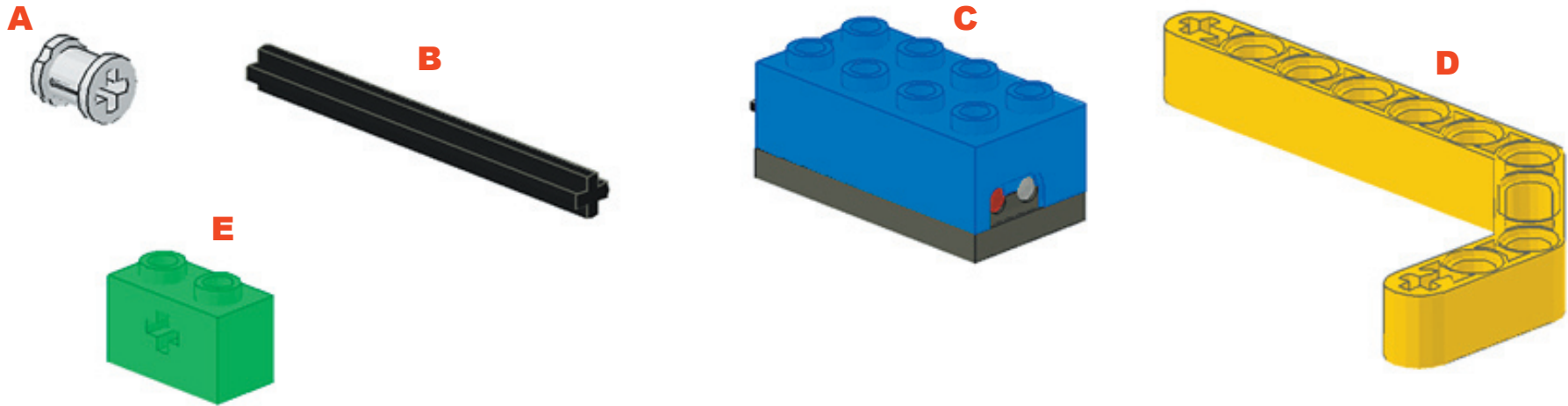

Full Bushing	A	-	4
6-Stud Axle	B	-	2
Light Sensor	C	-	1
Double Angular Beam	D	-	2
1x2 Brick w/cross hole	E	-	4

Light Sensor Attachment Page 1

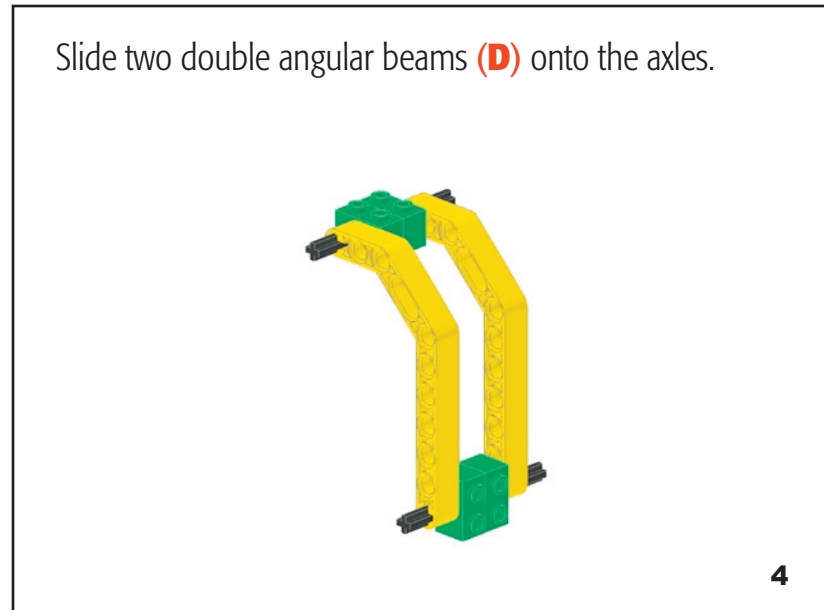
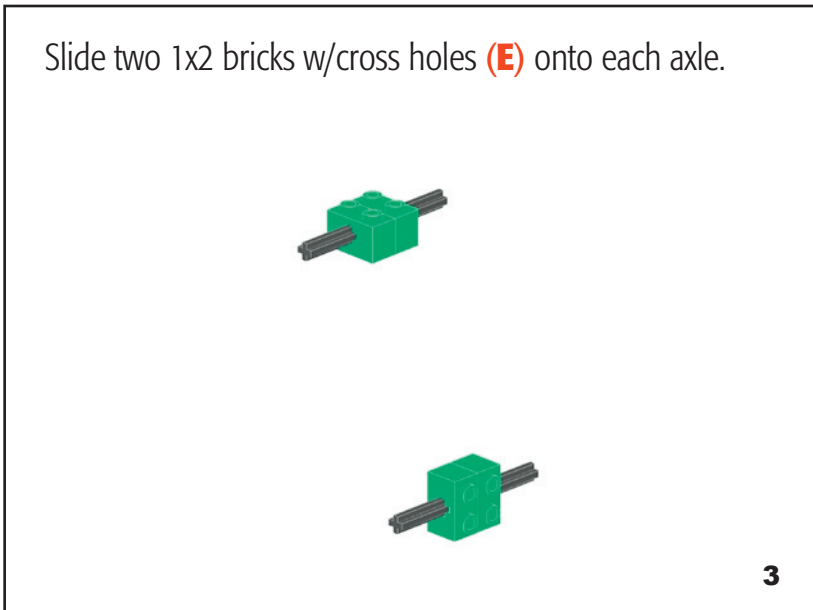
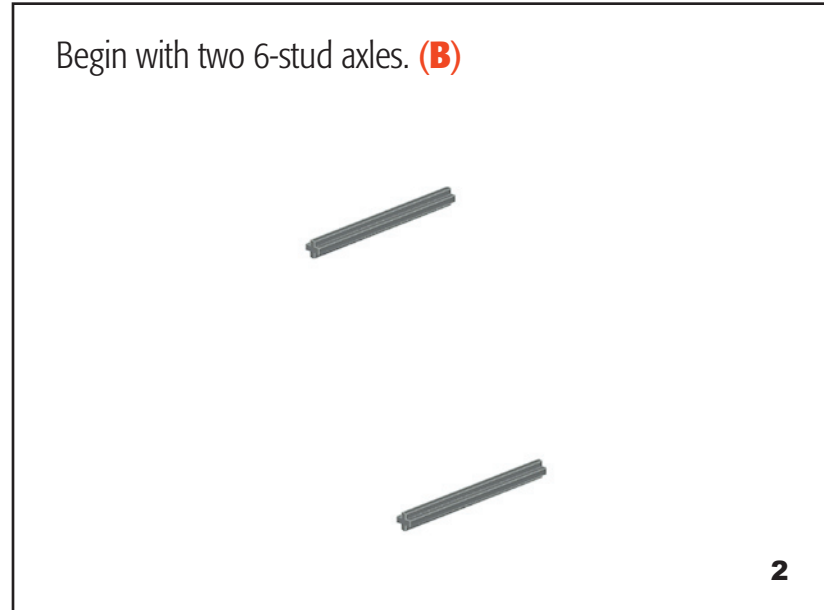

Light Sensor Attachment Page 2

Slide four full bushings (A) onto the axles.

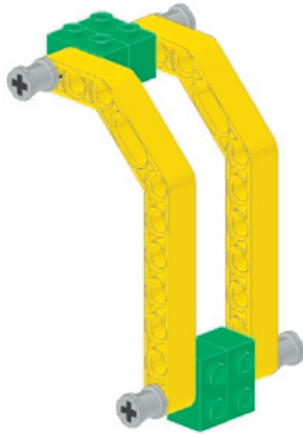

5

Add the light sensor (C). Attach this assembly to your robot so the sensor connecting lead fits onto sensor port 2 of the RCX.

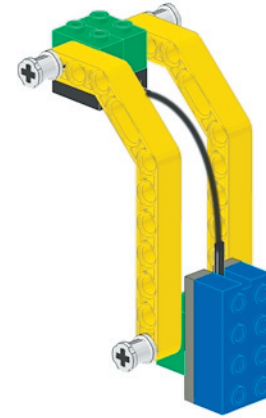

The **LIGHT SENSOR** is now complete.

6